



Master-Craft
Home Building Made Easy™

Freedom Series
Single Section
Floorplans

Meet Master-Craft: homes for today built on a legacy of quality and value.

Ritz-Craft is excited to include the Master-Craft series of home designs based on our commitment to our company's heritage. Founded in 1954, Ritz-Craft remains a family owned and operated company with a mission to provide quality and affordable housing solutions nationwide. Our daily focus is on the needs of our customers. Ritz-Craft is proud to have earned a reputation in the building industry for providing unmatched value for home builders and their home buyers.

In today's economy, as the price for labor and material continue to rise, it can be difficult for home builders to provide families with a quality home within their budget. Our mantra of "Home Building Made Easy," for the Master-Craft collection challenges us to provide high-value, single and double section manufactured homes and simplified modular designs as our daily mission.

As a result, we are proud to note that the standard construction of Master-Craft collection products will provide many value-added:



- Architectural Shingles
- White Pre-Finished 'Craftsman Style' Molding Package
- Smooth Finished Drywall Ceilings
- European-Style Frameless Cabinets
- 16" O.C. Wall Construction with 2x6 Exterior Walls
- A broad offering of packages, options, and selections
- Quality standards and materials that distinguish Master-Craft from other brands available in this market segment

All Master-Craft collection plans will be backed by Ritz-Craft's company-wide quality commitment. We're proud of this new, reimagined line of manufactured housing solutions and we are grateful for the opportunity to deliver you a Master-Craft home.

European Technology Meets American Craftsmanship

Legacy Crafted Cabinets, a member of the Ritz-Craft family of companies has created an entirely new line of cabinetry solutions for the Master-Craft collection of homes. The new Legato Cabinetry boasts an imaginative, frameless cabinet construction, as well as several value-added standards:

- Full-storage access
- Soft-close and self-close doors and drawers
- Adjustable base and overhead shelves with metal shelf clips
- Three standard colors, including white, gray, and a modern wood grain finish.

The look and functionality of quality cabinetry is at the heart of every home, and Legato Cabinetry by Legacy Crafted Cabinets is prove that it is possible to maintain affordability without sacrificing form or limiting function.

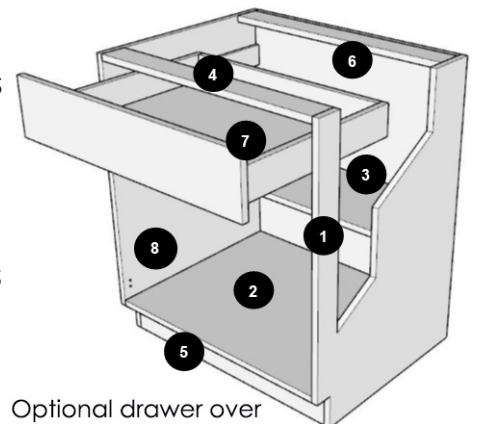

Optional drawer over door construction shown

Legato
CABINETS

Freedom Series Single-wide Floorplans

The Master-Craft Freedom Series features a collection of stylish and functional single-section house plans perfect for those who want to build a value-engineered home.

As with the entire Master-Craft collection, Freedom Series plans are designed to be affordably built, while maintaining standards for energy efficiency and material quality. Your new home will include quality building products for low maintenance, reliable performance and lasting value.



Spacious Design



Appealing Interior Design



Built-In Fireplace Options



Kitchen Options



Standard Elevation

Jay1648
 2 Bedroom
 1 Bath
 736 sq. ft.

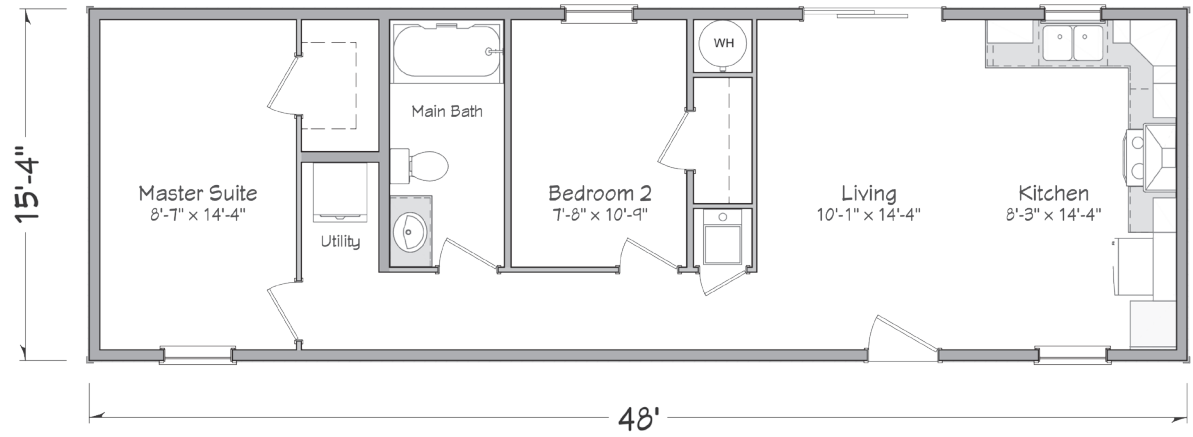

Jay1448
 2 Bedroom
 1 Bath
 640 sq. ft.

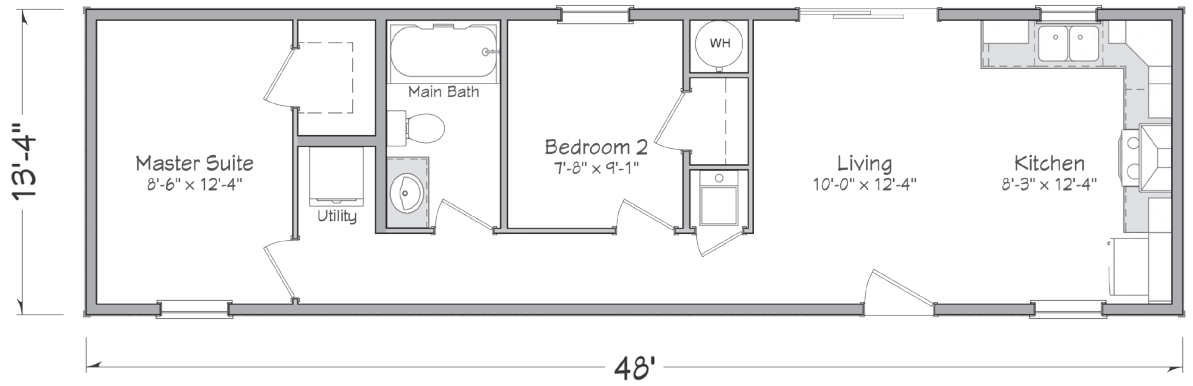

Hamilton1652
 2 Bedroom
 1 Bath
 797 sq. ft.

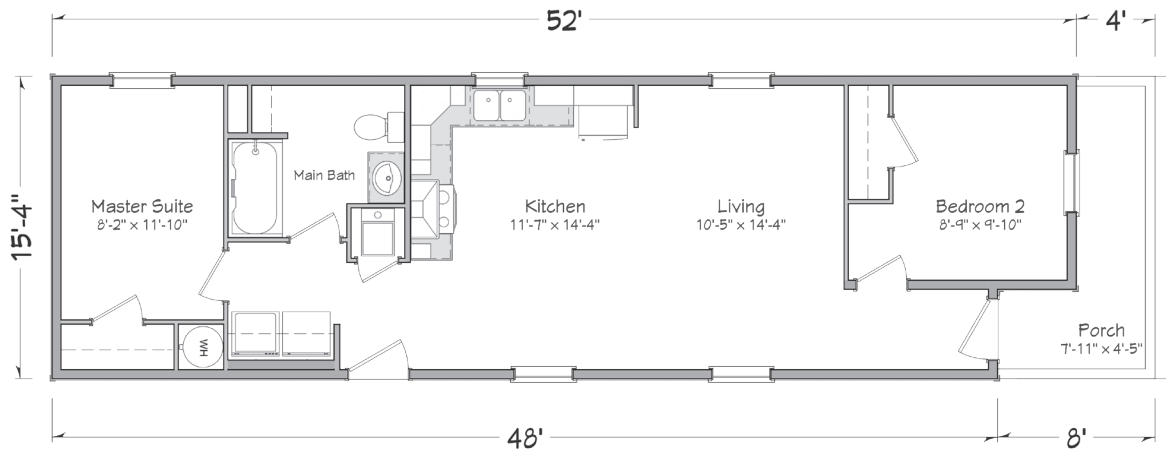

Hamilton1452
 2 Bedroom
 1 Bath
 720 Sq Ft

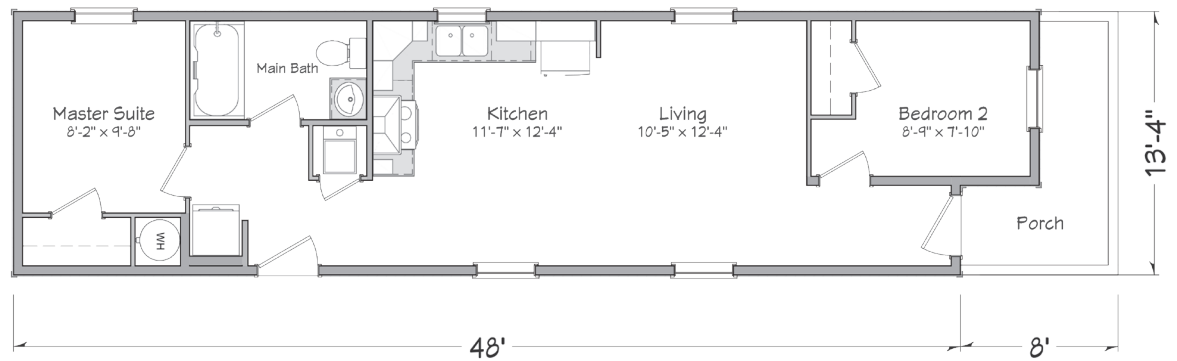

Burr1658
 2 Bedroom
 2 Bath
 889 sq. ft.

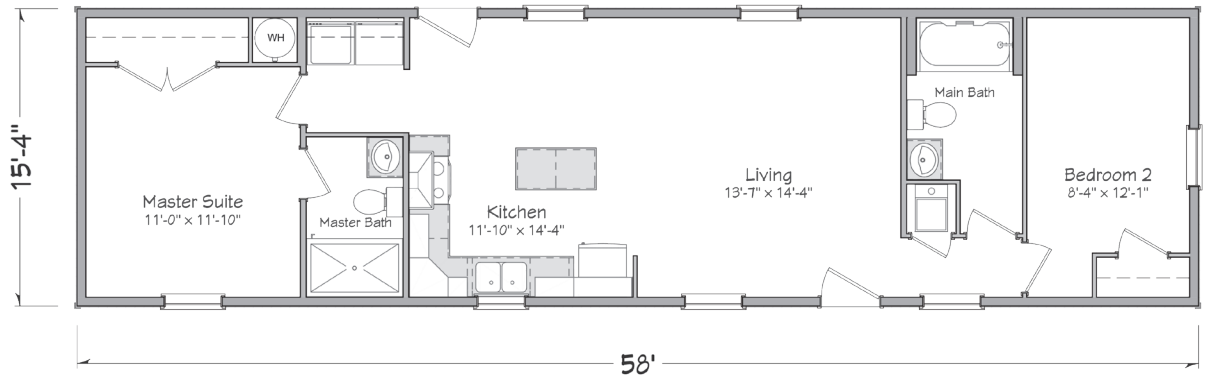

Burr1458
 2 Bedroom
 2 Bath
 773 sq. ft.

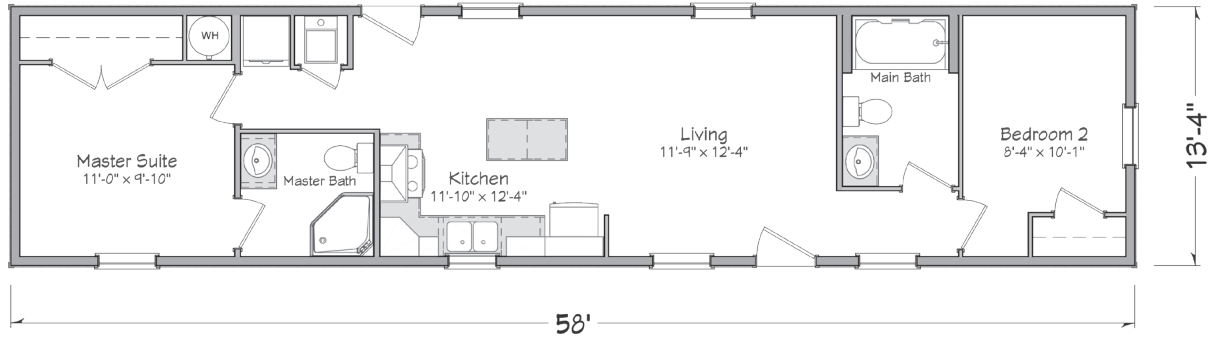

Revere1660
 2 Bedroom
 1 Bath
 920 sq. ft.

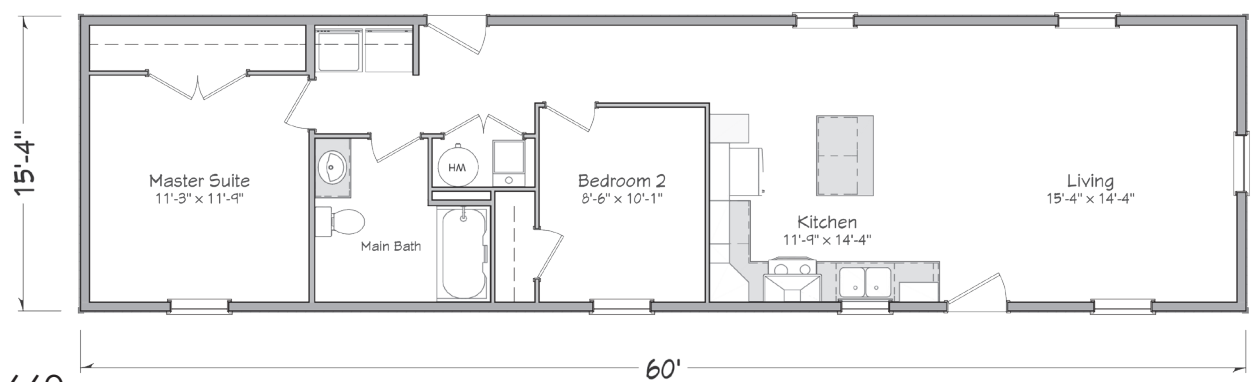

Revere1660
 2 Bedroom
 1 Bath
 800 sq. ft.

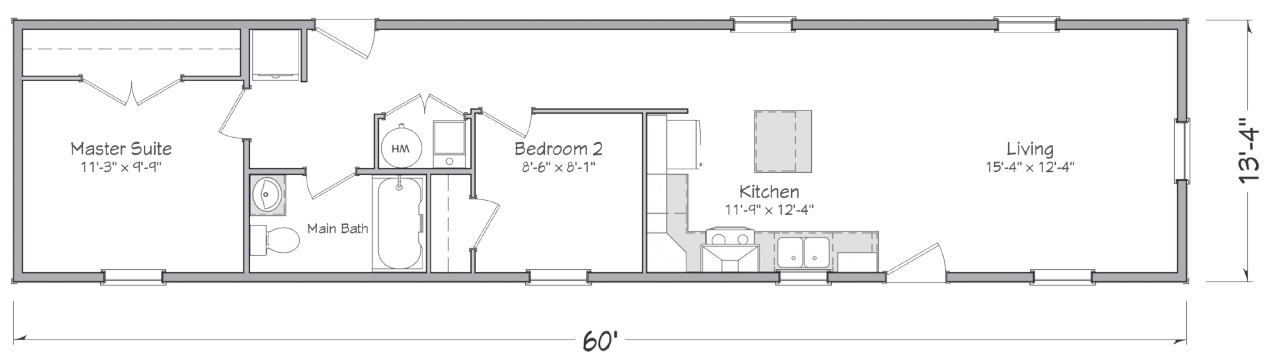

Clarke1662
 2 Bedroom
 2 Bath
 951 sq. ft

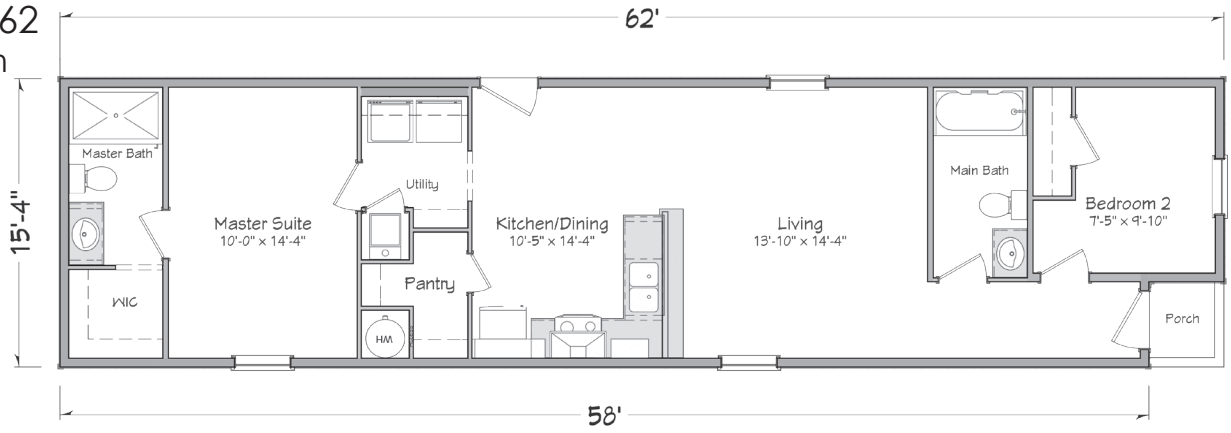

Clarke1462
 2 Bedroom
 2 Bath
 826 sq. ft

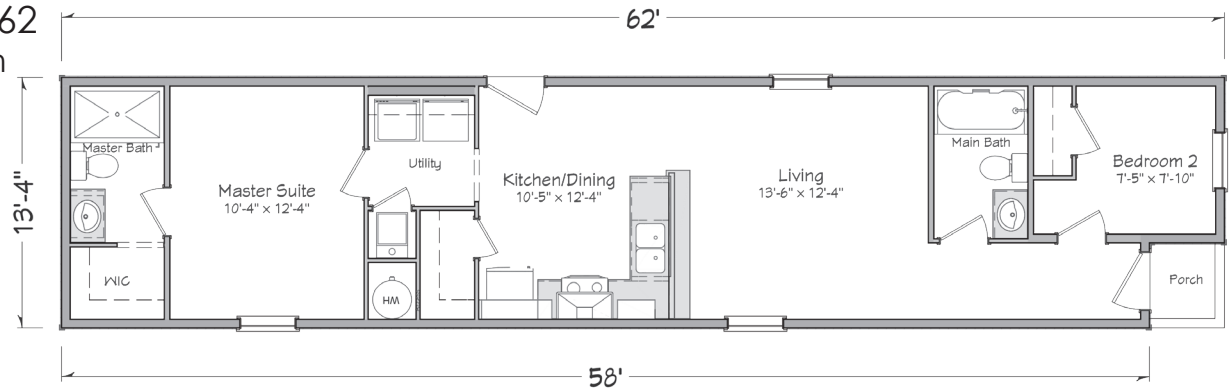

Adams1666
 3 Bedroom
 1 Bath
 1012 sq. ft.

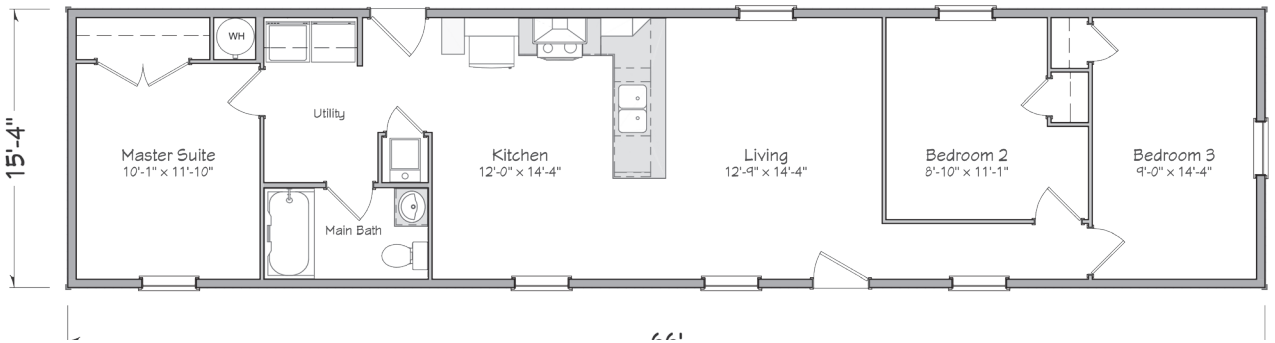

Adams1466
 3 Bedroom
 1 Bath
 880 sq. ft.

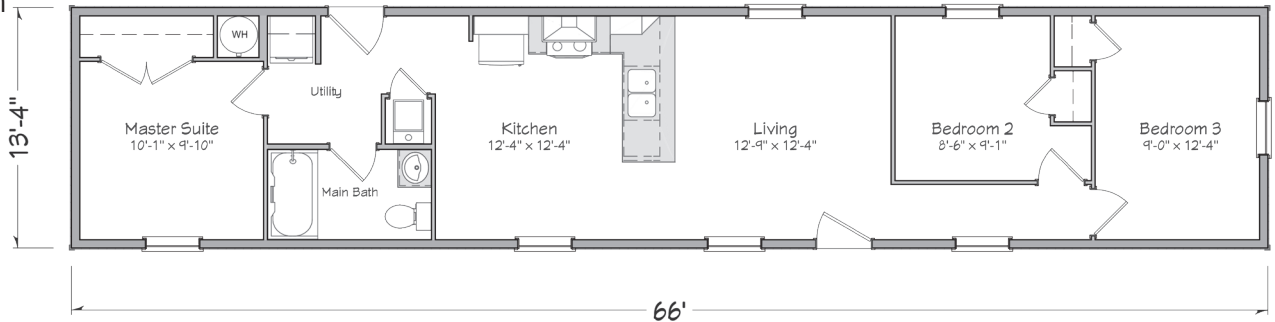

Greene1666

2 Bedroom

2 Bath

1012 sq. ft.

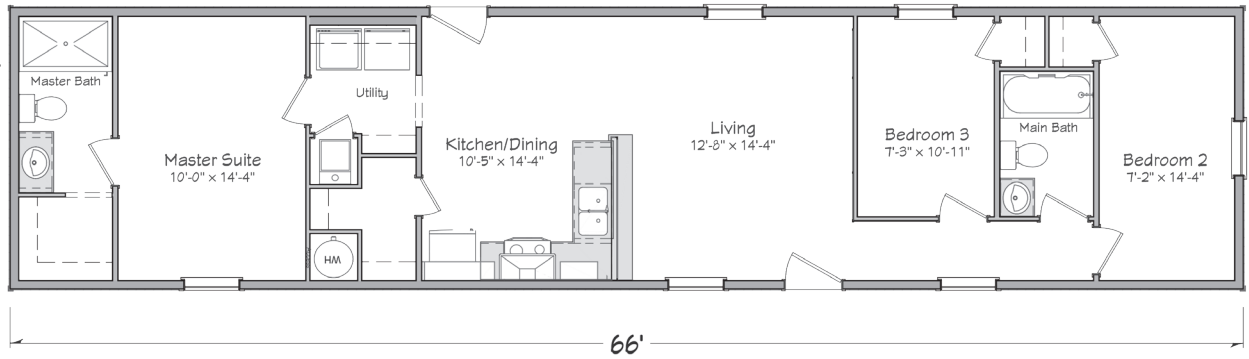

Greene1466

2 Bedroom

2 Bath

880 sq. ft.

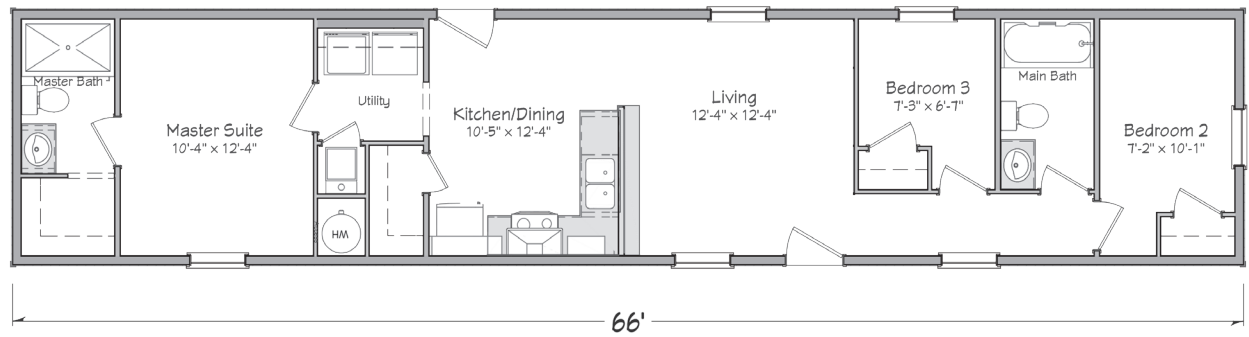

Henry1666

2 Bedroom

2 Bath

1012 sq.ft.

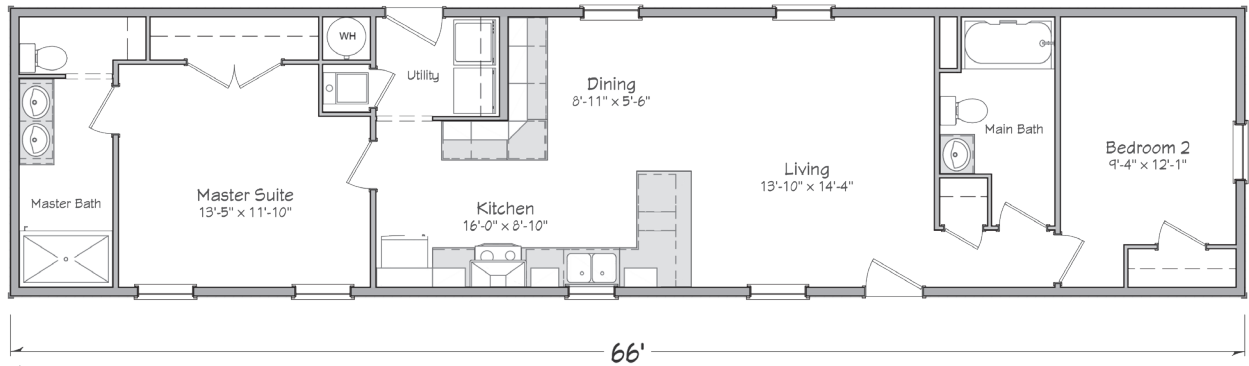

Henry1466

2 Bedroom

2 Bath

880 sq.ft.

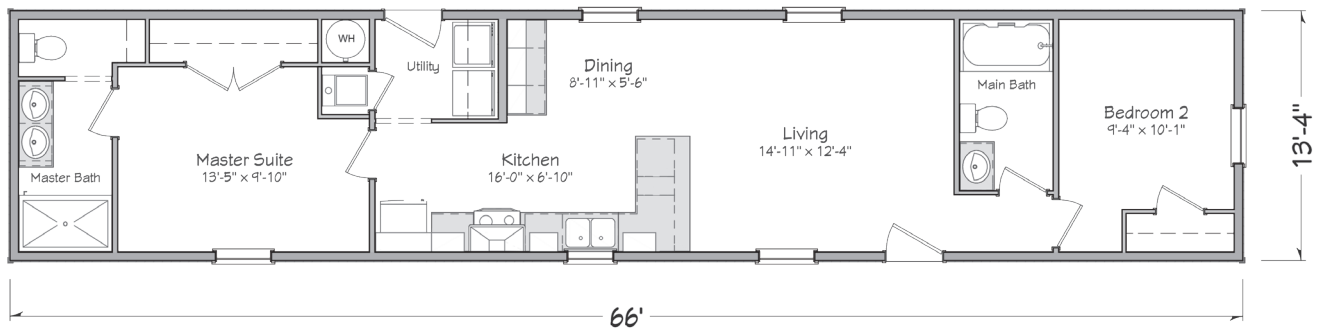

Paine1666

3 Bedroom

2 Bath

1012 sq. ft.

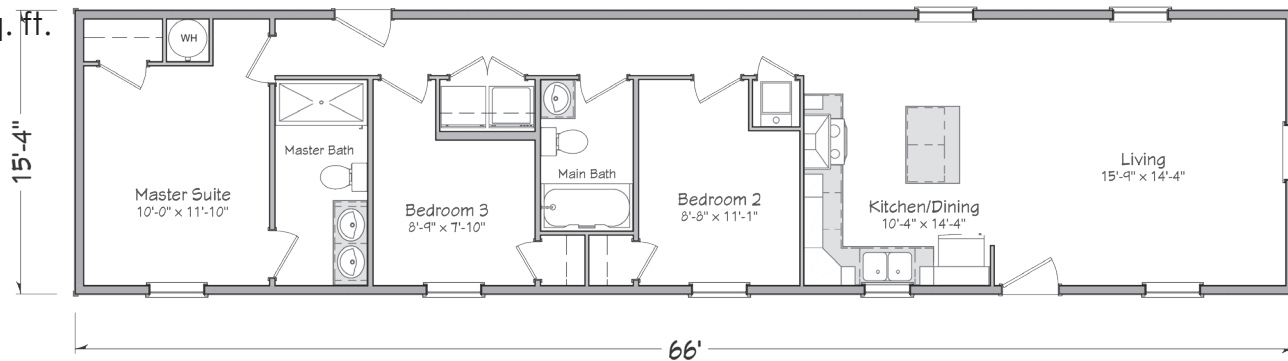

Paine1466

3 Bedroom

2 Bath

880 sq. ft.

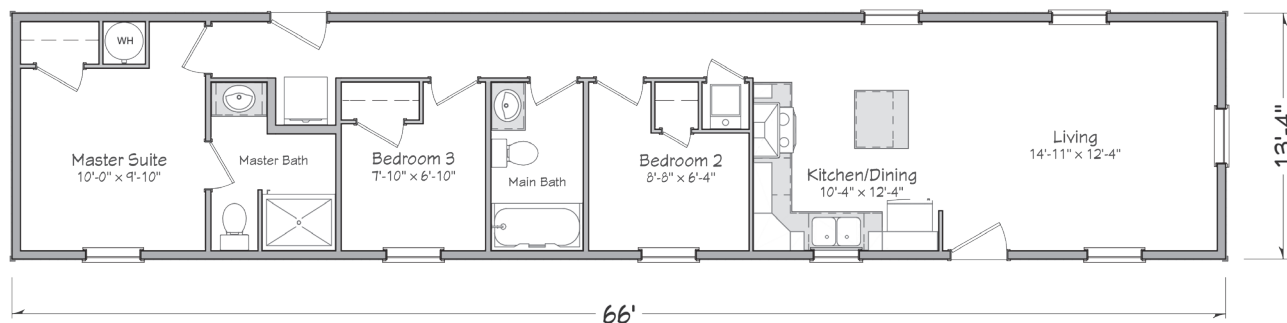

Shiple1672

3 Bedroom

2 Bath

1104 sq. ft.

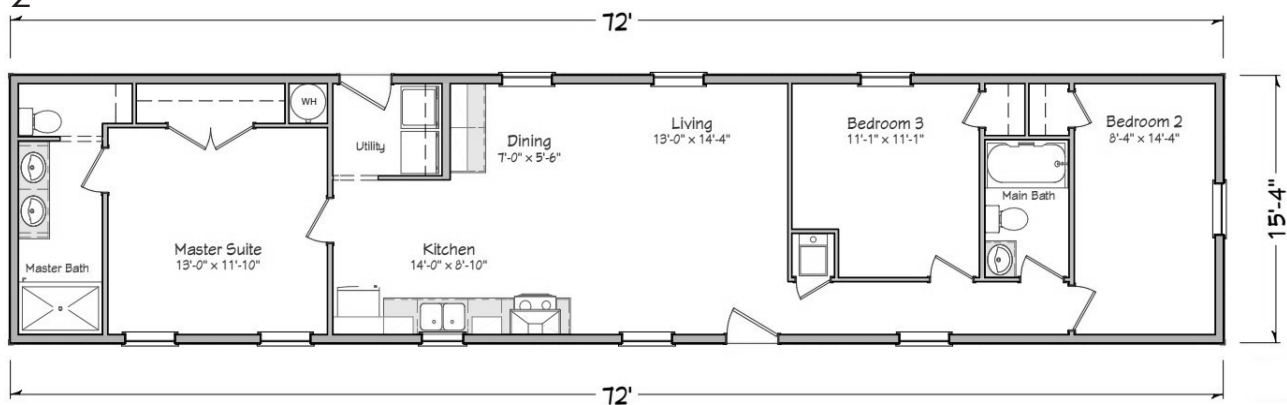

Shiple1472

3 Bedroom

2 Bath

960 sq. ft.

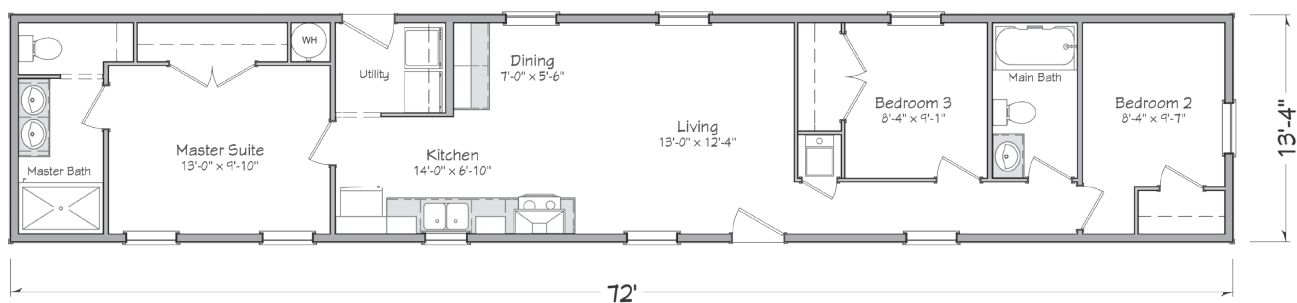

Trumbull 1672

2 Bedroom

2 Bath

1104 sq. ft.

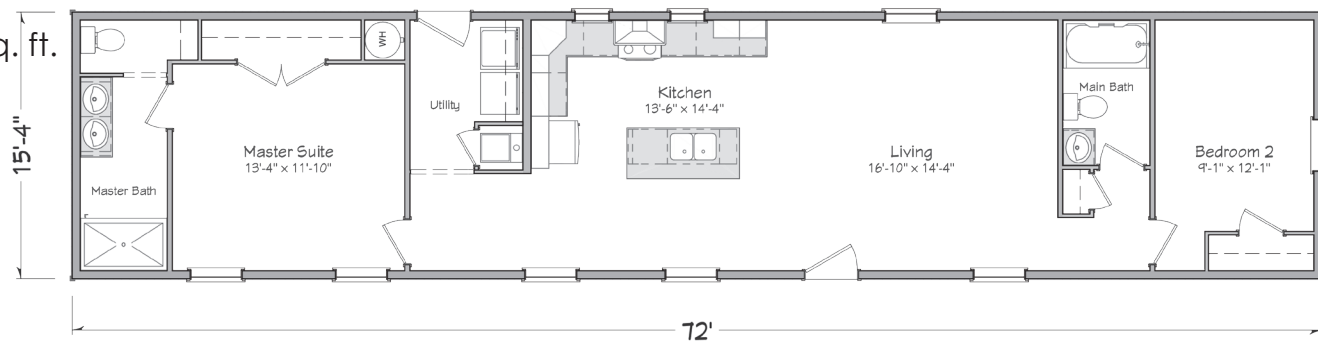

Trumbull 1472

2 Bedroom

2 Bath

960 sq. ft.

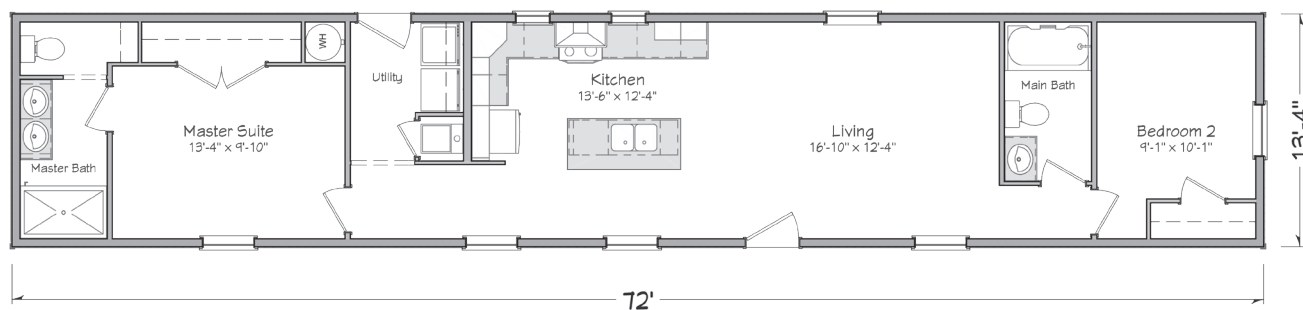

Hopkins 1676

3 Bedroom

2 Bath

1165 sq. ft.

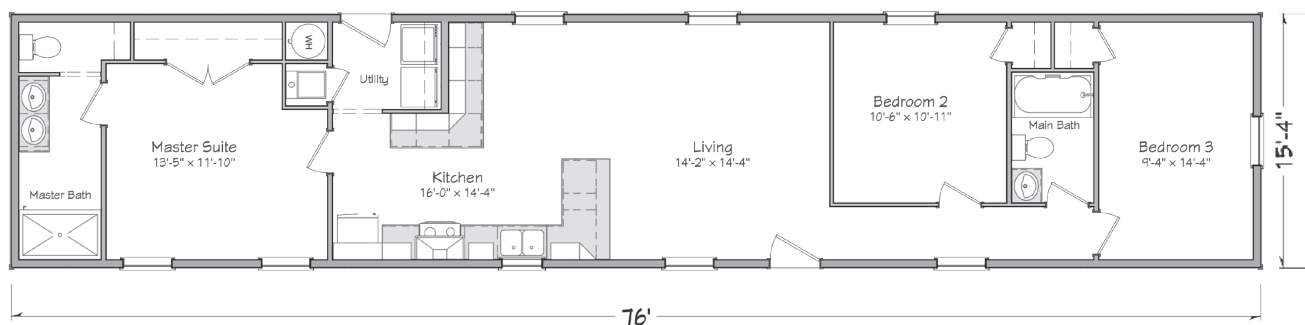

Hopkins 1476

3 Bedroom

2 Bath

1013 sq. ft.

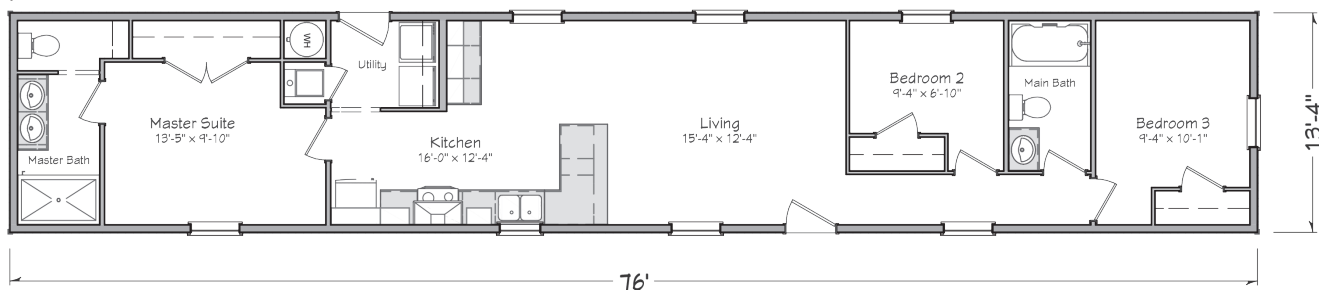

Matlack1676

3 Bedroom

2 Bath

1165 sq. ft.

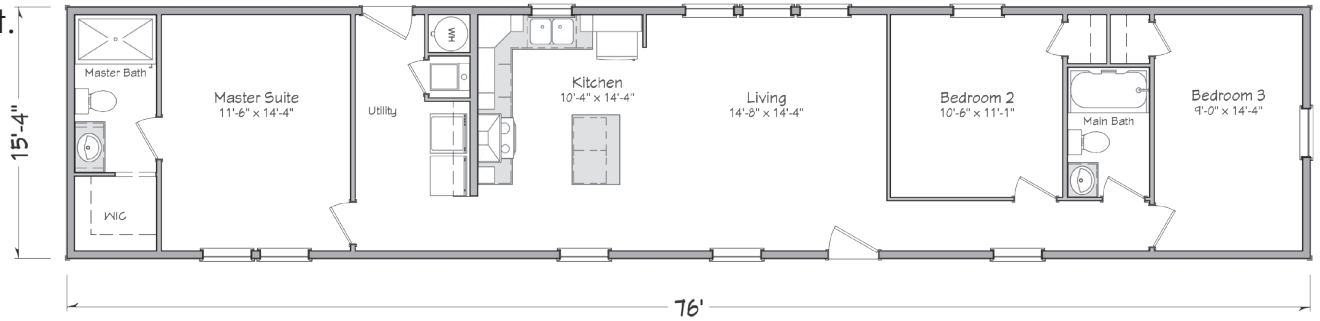

Matlack1476

3 Bedroom

2 Bath

1013 sq. ft.

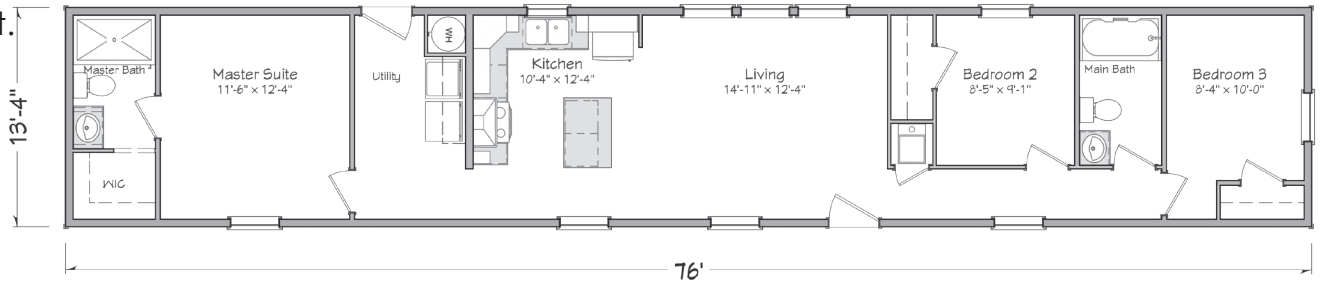

Sumter1676

3 Bedroom

2 Bath

1165 sq. ft.

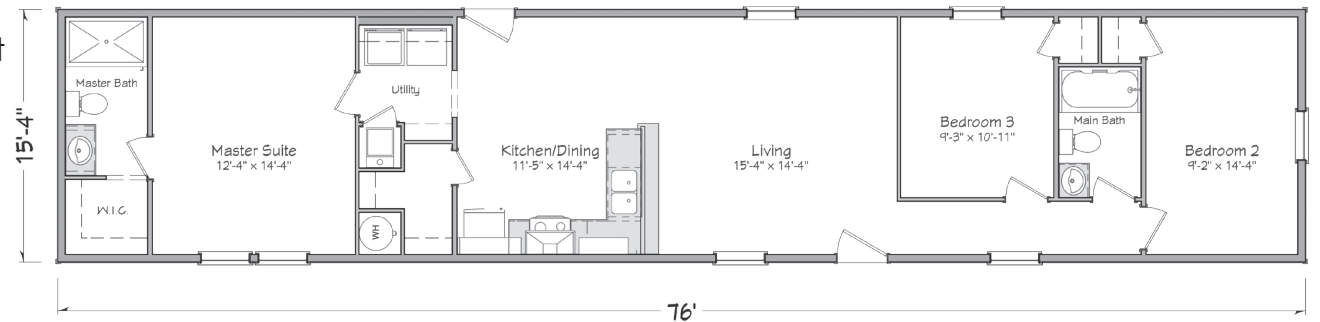

Sumter1476

3 Bedroom

2 Bath

1013 sq. ft.

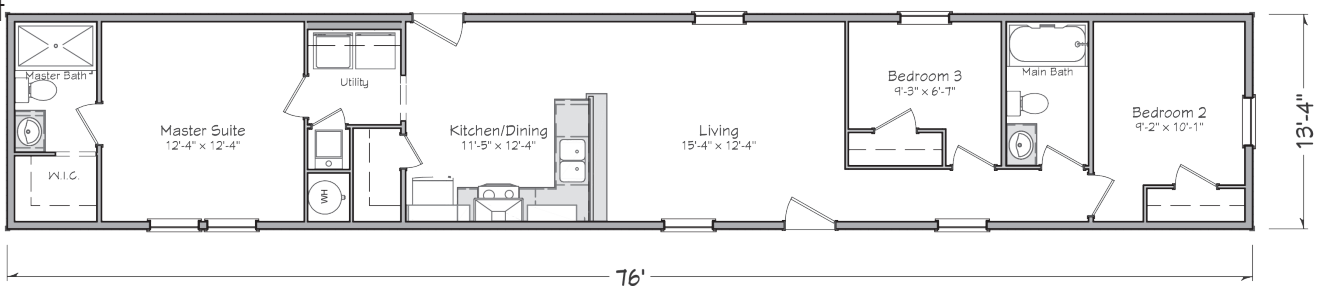

Master-Craft

Home Building Made Easy™





Approved homebuilders are independent business entities and are not agents of Master-Craft Corporation or its subsidiaries.

Due to occasional updating of building codes and Master-Craft's continuous product improvement, specifications are subject to change without prior notification. Be sure to request a copy of current specifications from your selected homebuilder.

© 2023 Ritz-Craft Corporation 062023